

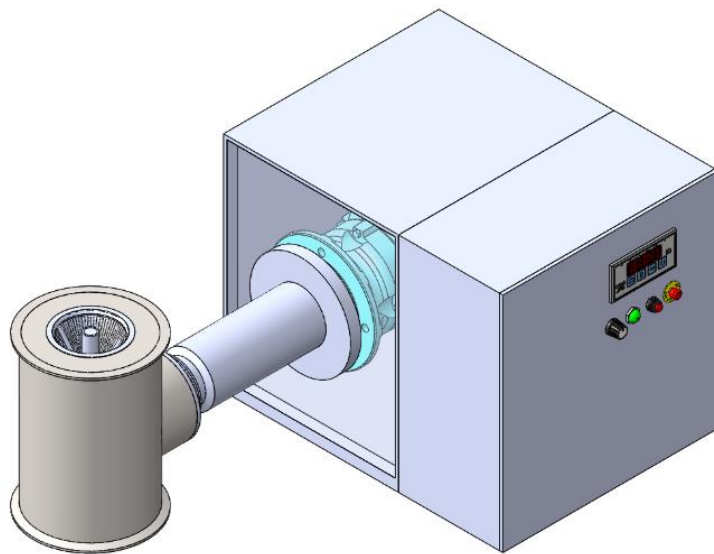

**FlowTech
Technologies Pvt Ltd.**

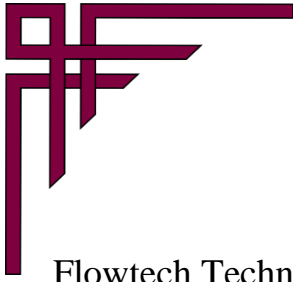

CONEMILL



ABOUT US

Flowtech Technologies is leading provider of plants and machinery to Pharmaceuticals, Chemicals, Cosmetics, Food, Beverages, Distilleries and allied industries. We are one of the best designing and manufacturing company in India who executes wide turn-key projects especially in Pharmaceutical industries.

Our Company is situated in Industrial area of Dombivli which have close proximity to Mumbai, Thane and Navi Mumbai with team of highly potential workers, qualified personnel, experienced technical staff who are in the field of design, manufacturer and execution of pharmaceutical, Chemical, Cosmetics and FMCG projects for a long time.

Flowtech guarantee excellent products & after sales service. With the latest software and manufacturing system Flowtech can provide cost effective product and solution to our customers. Our team make sure that each instrument is inspected & assured under USP & FDA guidelines.

As a design build company, Flowtech can design and install your process plant & piping project. Our highly skilled engineering and design department has the experience and technical expertise to help you develop your project from the ground up. Our design team will design your project to your specifications, while suggesting options that can save you money and time.

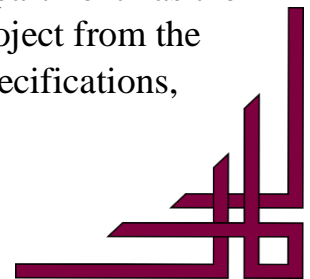

CONEMILL

A conical mill (or conical screen mill) is a machine used to reduce the size of material in a uniform manner

As the name implies, the conical mill varies in diameter from where the feed enters to where the product exits.

The conical mill operates by having the product being fed into the mill by gravity or vacuum. A rotating impeller forces the material outward to a conical screen surface, where it is sized and passed through the openings in the screen.

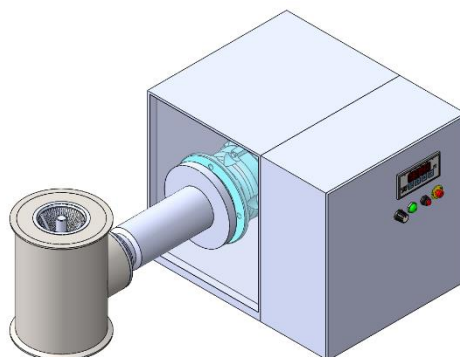

Once finished, the product simply drops through the milling chamber to a receptacle underneath.

Our Features

- ✦ Variant capacities (50 kgs / hr – 500 kgs / hr)
- ✦ Better efficiency & higher output
- ✦ Integratable units for convenience
- ✦ Mobile units
- ✦ Better designs for low noise operation

TECHNICAL SPECS

Model	Screen Size (mm)	Capacity (Kgs/Hr)	Motor (HP)
Lab	83	Upto 50	1
Pilot	122	Upto 100	2
Production	200	Upto 250	3
	300	Upto 500	5

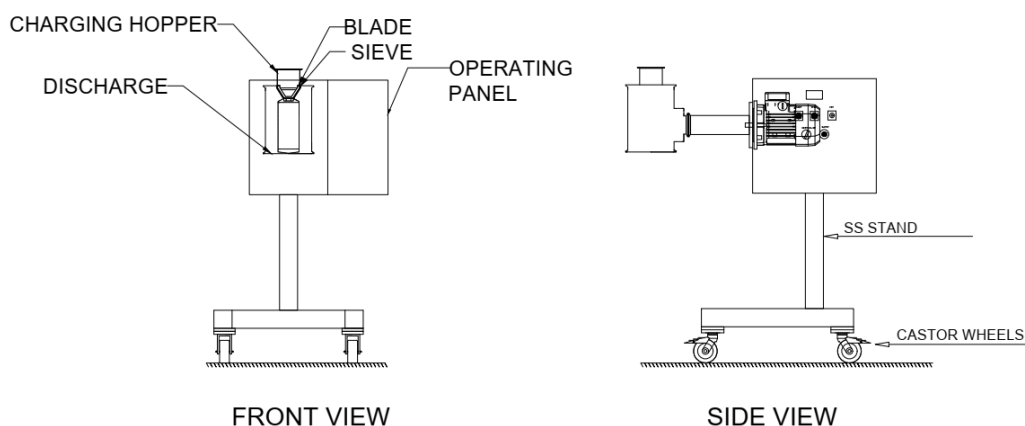



Plot No. - B-21, MIDC Phase-1, Opp Krishna Hotel
Dombivali (E), Thane- 421 203, Mumbai
Tel: +91 916 786 2055 / 66 / 0251 2990227
Email - info@[flowtechtechnologies.com](mailto:info@flowtechtechnologies.com)
Web - www.flowtechtechnologies.com